

Dual hygrometer(Analogue) TDC-911-PX (Capacity 837L)

NOMENCLATURE

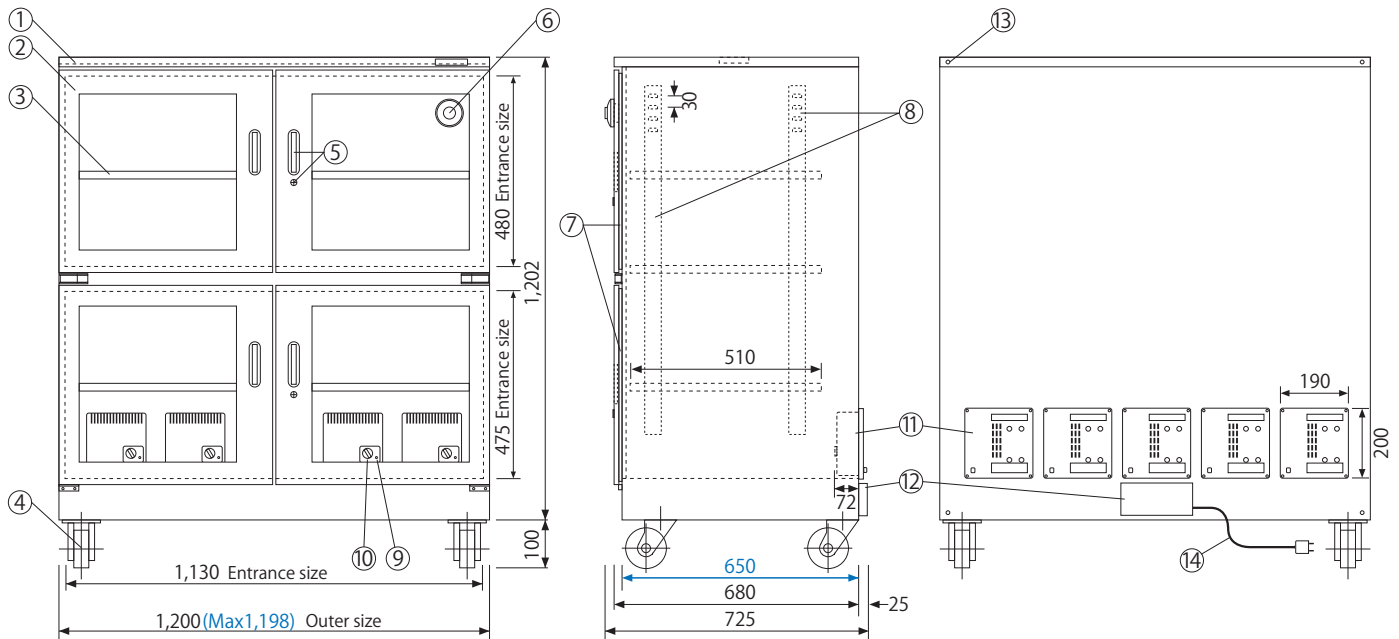

- ◆ Blue number indicates the dimensions of storage space.
- ◆ Each shelf board is adjustable, and is removable for your convenience.

Name	Specification
① Cabinet	: High quality steel plate (1.0mm), hard coated with melamine silver metallic resin (Silver color).
② Door	: 4 doors, steel made, with clear glass and magnetic packing.
③ Shelf	: Steel board 3pcs
④ Caster	: 4 casters, with stopper only front 2 casters
⑤ Handle	: 4 handles, 2 locks with key (2pcs)
⑥ Hygrometer	: Analogue Dual, humidity shown both inside (upper indicator) and outside (bottom indicator) housing
⑦ Magnet paking	: Door packing with magnet ensures air tightness
⑧ Pillar for hook	: For setting shelf board
⑨ Pilot lamp	: Lighting during the exhaust, lights out during the moisture absorption
⑩ Controller	: Humidity controller
⑪ Dry unit (5)	: Dehumidifier, desiccant system, latest high and technological Memory alloy, IC timer, with a humidity controller for only dehumidifying.
⑫ Terminal box cover	: Connecting cords of Dry Unit.
⑬ Spare screw	: Double layer connection screw, wall hung tip-resistant hook.
⑭ Power source	: AC100~120V 50/60Hz 0~18W/H (Max 600W/moment) AC220~240V 50/60Hz 0~9W/H (Max 300W/moment) The absorption & ventilation cycle of new drying unit upgraded to 4 hours (3 hours and 30 minutes absorption and 30 minutes ventilation).
Weight	: 87Kg



*Note: Specification are subject to change without notice