

Digital Dual LED Hygrometer TDC-910-DDX (Capacity 837L)

NOMENCLATURE

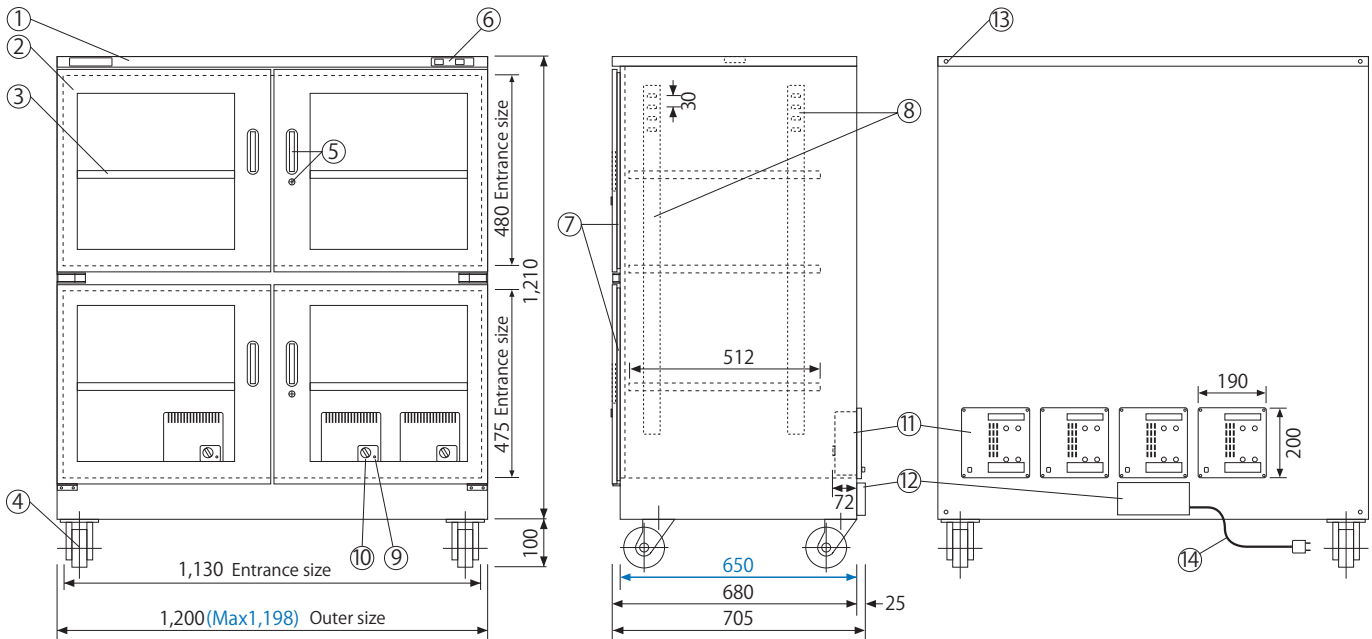

- ◆ Blue number indicates the dimensions of storage space.
- ◆ Each shelf board is adjustable, and is removable for your convenience.

| Name | Specification |
|----------------------|---|
| ① Cabinet | : High quality steel plate (1.0mm), hard coated with melamine silver metallic resin (Silver color). |
| ② Door | : 4 doors, steel made, with clear glass and magnetic packing. |
| ③ Shelf | : Steel board 3pcs |
| ④ Caster | : 4 casters, with stopper only front 2 casters |
| ⑤ Handle | : 4 handles, 2 locks with key (2pcs) |
| ⑥ Hygrometer | : Digital Dual LED hygrometer, humidity shown both inside and outside housing |
| ⑦ Magnet paking | : Door packing with magnet, ensures air tightness |
| ⑧ Pillar for hook | : For setting shelf board |
| ⑨ Pilot lamp | : Lighting during the exhaust, lights out during the moisture absorption |
| ⑩ Controller | : Humidity controller |
| ⑪ Dry unit (4) | : Dehumidifier, desiccant system, latest high and technological Memory alloy, IC timer, with a humidity controller for only dehumidifying. |
| ⑫ Terminal box cover | : Connecting cords of Dry Unit. |
| ⑬ Spare screw | : Double layer connection screw, wall hung tip-resistant hook. |
| ⑭ Power source | : AC100~120V 50/60Hz 0.3W/H~14.4W/H (Max 480W/moment) AC220~240V 50/60Hz 0.15W/H~7.2W/H (Max 240W/moment) The absorption & ventilation cycle of new drying unit upgraded to 4 hours (3 hours and 30 minutes absorption and 30 minutes ventilation). |
| Weight | : 86Kg |

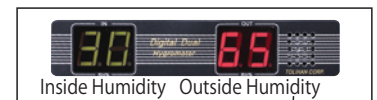

*Note: Specification are subject to change without notice