

Dual hygrometer(Analogue) TDC-500-AX (Capacity 485L)

NOMENCLATURE

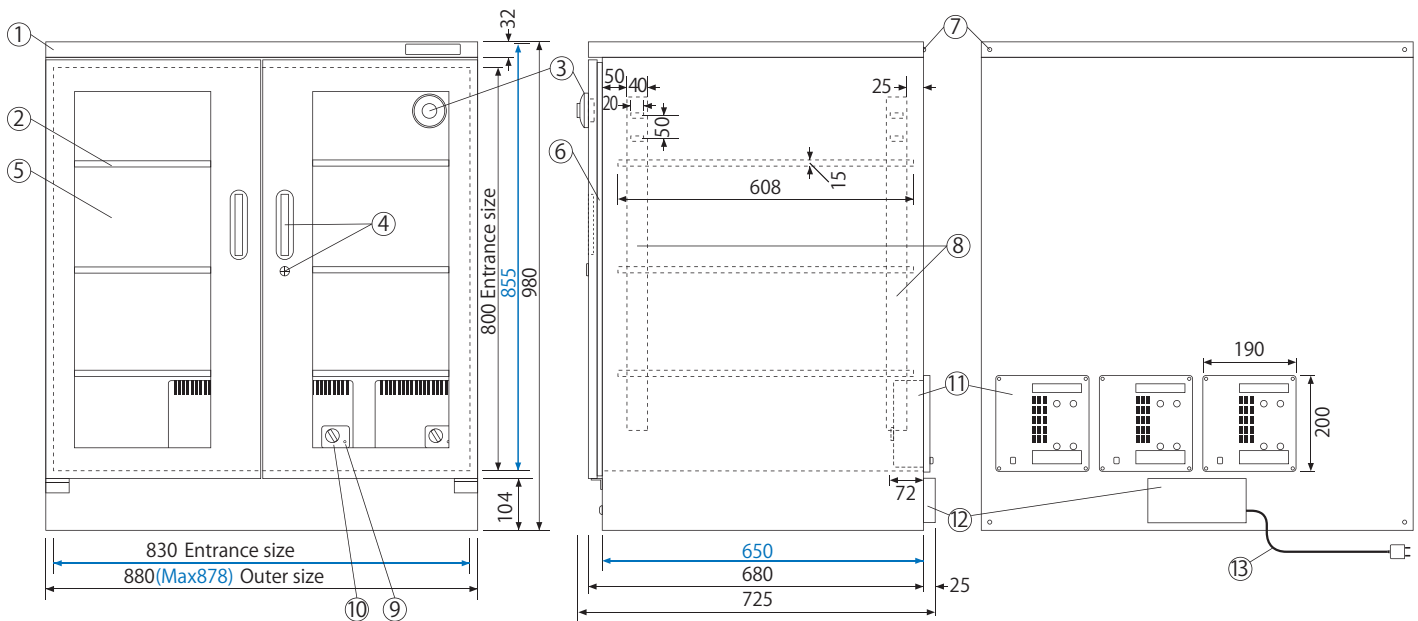

- ◆ Blue number indicates the dimensions of storage space.
- ◆ Each shelf board is adjustable, and is removable for your convenience.

Name	Specification
① Cabinet	: High quality steel plate (0.8mm), hard coated with melamine silver metallic resin (Silver color).
② Shelf	: Steel board 3pcs
③ Hygrometer	: Analogue Dual, humidity shown both inside (upper indicator) and outside (bottom indicator) housing
④ Handle	: 2 handles, lock with key (2pcs)
⑤ Door	: 2 doors, steel made, with clear glass and magnetic packing.
⑥ Magnet paking	: Door packing with magnet ensures air tightness
⑦ Spare screw	: Double layer connection screw, wall hung tip-resistant hook.
⑧ Pillar for hook	: For setting shelf board
⑨ Pilot lamp	: Lighting during the exhaust, lights out during the moisture absorption
⑩ Controller	: Humidity controller
⑪ Dry unit (3)	: Dehumidifier, desiccant system, latest high and technological Memory alloy, IC timer, with Humidity controller for only dehumidifying.
⑫ Terminal box cover	: Connecting cords of Dry Unit.
⑬ Power source	: AC100~120V 50/60Hz 0~10.8W/H (Max 360W/moment) AC220~240V 50/60Hz 0~5.4W/H (Max 180W/moment) The absorption & ventilation cycle of new drying unit upgraded to 4 hours (3 hours and 30 minutes absorption and 30 minutes ventilation).
Weight	: 67Kg



*Note: Specification are subject to change without notice