

WET-CABI Humidify
TDC-500-AHU (Capacity 485L)

NOMENCLATURE

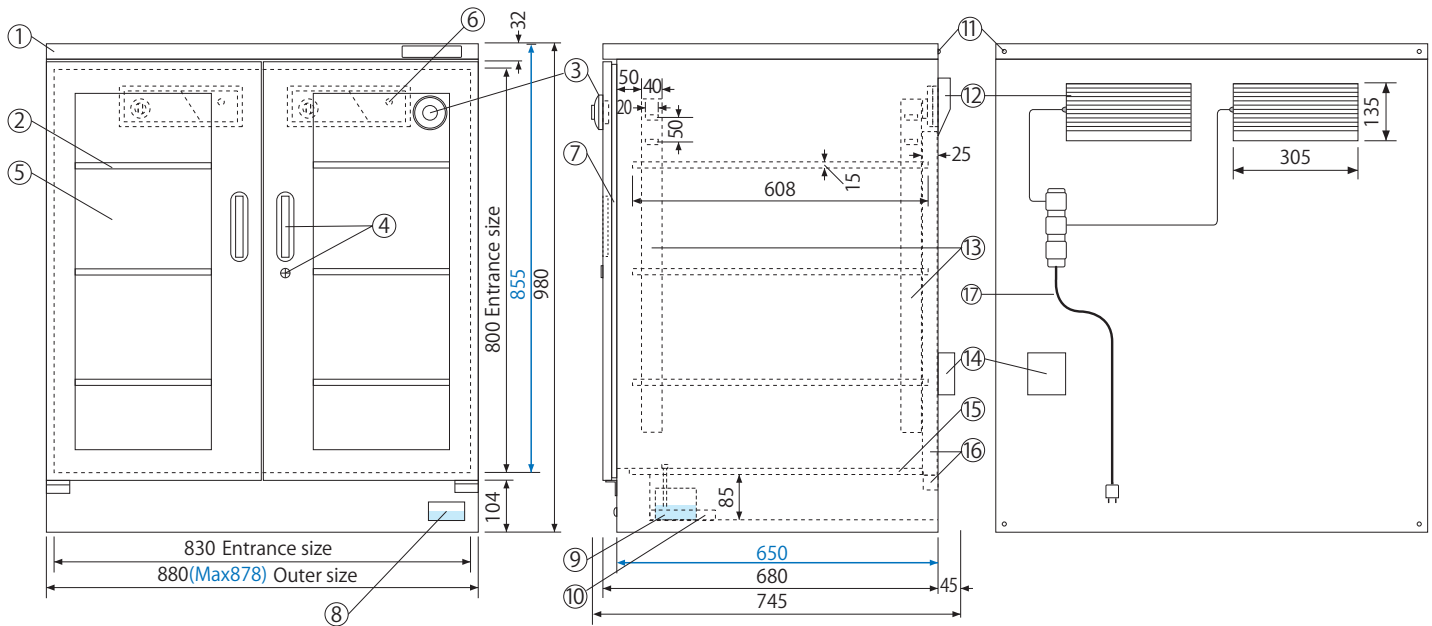

- ◆ Blue number indicates the dimensions of storage space.
- ◆ Each shelf board is adjustable, and is removable for your convenience.

Name	Specification
① Cabinet	: High quality steel plate (0.8mm), hard coated with melamine silver metallic resin (Silver color).
② Shelf	: Steel board 3pcs
③ Hygrometer	: Analogue Dual, humidity shown both inside (upper indicator) and outside (bottom indicator) housing
④ Handle	: 2 handles, lock with key (2pcs)
⑤ Door	: 2 doors, steel made, with clear glass and magnetic packing.
⑥ Pilot lamp	: Lighting during the exhaust, lights out during the moisture absorption
⑦ Magnet packing:	Door packing with magnet ensures air tightness
⑧ Window	: Water level confirmation window
⑨ Tray	: Water container for humidification
⑩ Tray	: Tray for overspill prevention of the water for humidification
⑪ Spare screw	: Double layer connection screw, wall hung tip-resistant hook.
⑫ Dry unit (2)	: Thermo Module Dehumidifying System, with Humidity controller
⑬ Pillar for hook	: For setting shelf board
⑭ Time switch	: Timer for Fan ON/OFF
⑮ Bottom plate	: Steel with punting hole for air circulation
⑯ Fan	: Fan for circulating in the storage. 6W/H.
⑰ Power source	: AC100~120V 50/60Hz 0W/H~26W/H AC220~240V 50/60Hz 0W/H~13W/H Energy saving dehumidifying system
Weight	: 85Kg



*Note: Specification are subject to change without notice