

ULTRA LOW Humidity, Anti-static with data logging function (option)
Digital LCD Hygrometer with thermometer

TDC-438-QA (Capacity 417L)

NOMENCLATURE

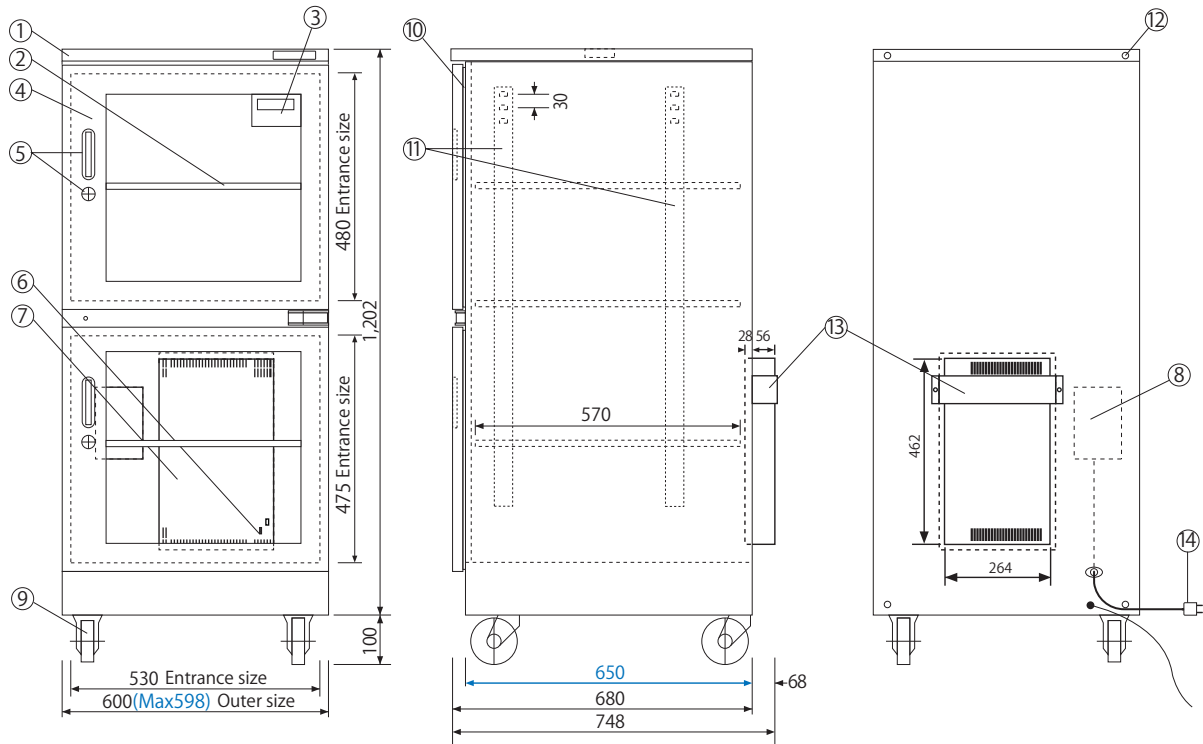

- ◆ Blue number indicates the dimensions of storage space.
- ◆ Each shelf board is adjustable, and is removable for your convenience.

Name	Specification
① Cabinet	: High quality steel plate (0.8mm), anti-static, hard coated with melamine silver metallic resin (Silver color).
② Shelf	: High quality steel plate (0.8mm), anti-static 3pcs
③ Hygrometer	: Digital LCD hygrometer, humidity and temperature indication. (Because it is with AC adapter, the battery is unnecessary) Data logging function (Soft for PC option) is possible.
④ Door	: 2Doors,Steel, with clear glass of anti-static and magnetic packing.
⑤ Handle	: 2 Handles,2Locks with key (2pcs)
⑥ Operation check lamp	: (TOP/Green lamp Lighting:absorption, MIDDLE/Red lamp Lighting: Reproduction exhaust, BOTTOM/Red lamp Lighting:For internal humidity Warning)
⑦ Dry unit	: Large dehumidifier, desiccant system, latest high and technological Memory, alloy, IC timer, with a humidity controller for only dehumidifying
⑧ Storage box	: Storage box for a power supply and a terminal board
⑨ Caster	: Electrifying caster (minimizing static buildup and dust bearing) Front caster with stopper
⑩ Magnet paking	: Door packing with magnet ensures air tightness
⑪ Spare screw	: Connection screw, wall hung tip-resistant hook.
⑫ Pillar for hook	: For setting shelf board
⑬ Shutter cover	: Guard shutter cover for dry-unit exhaustion
⑭ Power source	: AC100~120V 50/60Hz 6W/H AC220~240V 50/60Hz 6W/H With outlet for use in cabinet, and 1MΩ earth cord Energy saving dehumidifying system, 460 minutes-cycle system-starting with 40 minutes exhaust and 60 minutes cooling, then 360 minutes moisture absorption.
Weight	: 55Kg



*Note: Specification are subject to change without notice



Since 1983

TOLIHAN CORP.

An inquiry, the communication by E-mail.

E-mail info@dry-cabi.co.jp

21-6, Higashi-Ueno, 3-chome, Taiko-ku, Tokyo Japan 110-0015

Phone:81-3-3833-0614 Fax:81-3-3833-0616

URL <http://www.dry-cabi.co.jp/english.html>