

Digital Dual LED Hygrometer TDC-430-DDX (Capacity 417L)

NOMENCLATURE

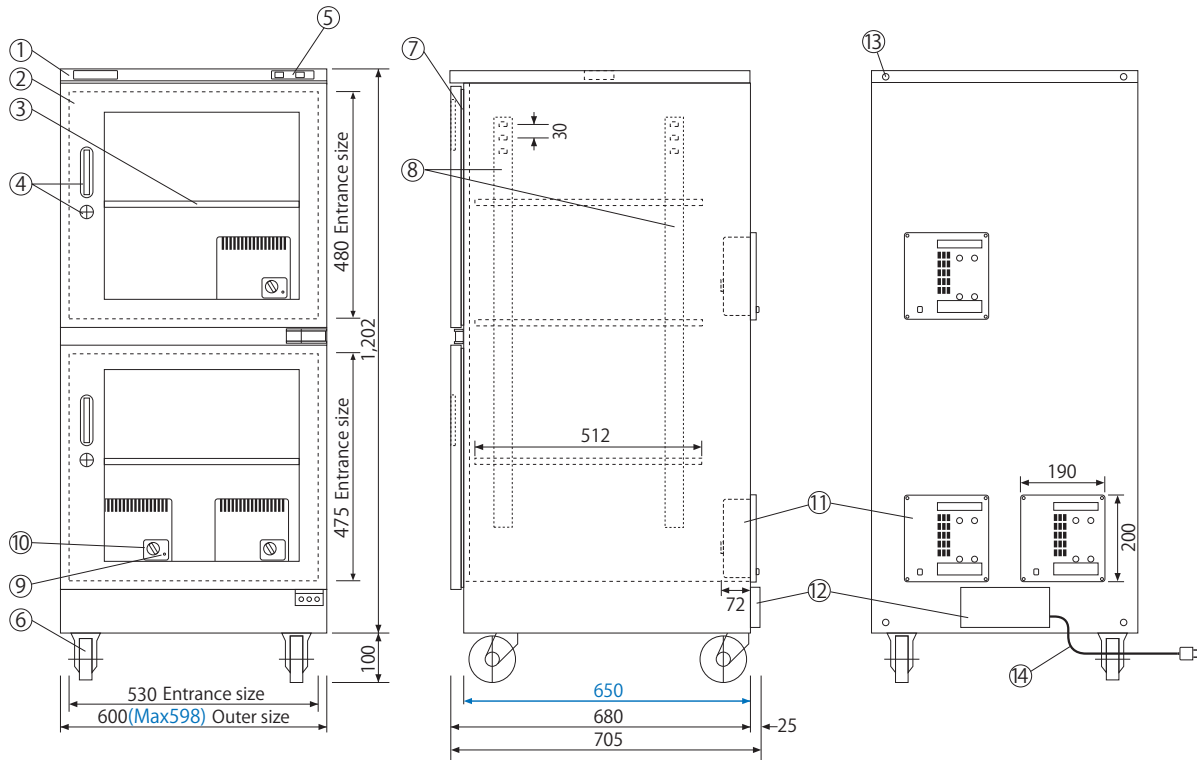

- ◆ **Blue number** indicates the dimensions of storage space.
- ◆ Each shelf board is adjustable, and is removable for your convenience.

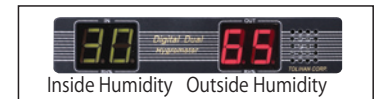

Name	Specification
① Cabinet	: High quality steel plate (1.0mm), hard coated with melamine silver metallic resin (Silver color).
② Door	: 2 doors, steel made, with clear glass and magnetic packing.
③ Shelf	: Steel board 3pcs
④ Handle	: 2 handles, 2 locks with key (2pcs)
⑤ Hygrometer	: Digital Dual LED hygrometer, humidity shown both inside and outside housing
⑥ Caster	: 4 casters, with stopper only front 2 casters
⑦ Magnet paking	: Door packing with magnet ensures air tightness
⑧ Pillar for hook	: For setting shelf board
⑨ Pilot lamp	: Lighting during the exhaust, lights out during the moisture absorption
⑩ Controller	: Humidity controller
⑪ Dry unit (3)	: Dehumidifier, desiccant system, latest high and technological Memory alloy, IC timer, with a humidity controller for only dehumidifying.
⑫ Terminal box cover	: Connecting cords of Dry Unit.
⑬ Spare screw	: Double layer connection screw, wall hung tip-resistant hook.
⑭ Power source	: AC100~120V 50/60Hz 0.3W/H~10.8W/H (Max 360W/moment) AC220~240V 50/60Hz 0.15W/H~5.4W/H (Max 180W/moment) The absorption & ventilation cycle of new drying unit upgraded to 4 hours (3 hours and 30 minutes absorption and 30 minutes ventilation).
Weight	: 51Kg



*Note: Specification are subject to change without notice