

ULTRA LOW Humidity
Dual hygrometer(Analogue)
TDC-159-QS (Capacity 145L)

NOMENCLATURE

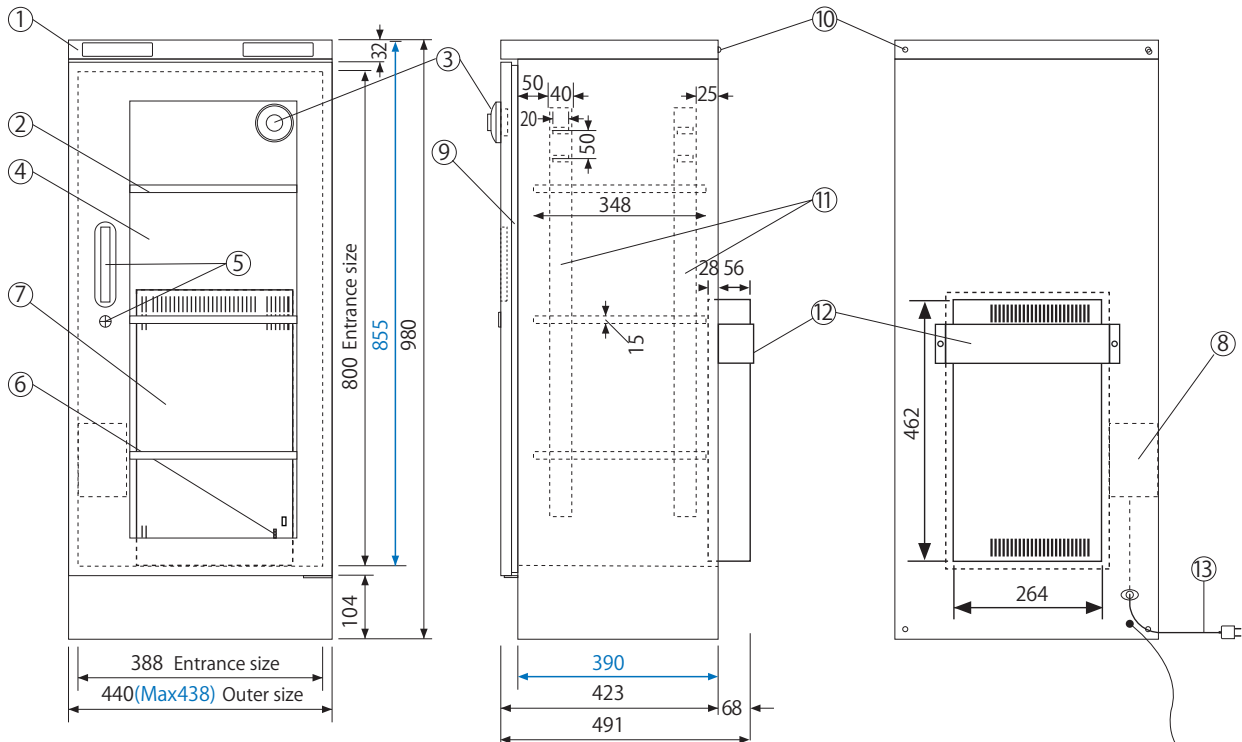

- ◆ Blue number indicates the dimensions of storage space.
- ◆ Each shelf board is adjustable, and is removable for your convenience.

Name	Specification
① Cabinet	: High quality steel plate (0.8mm), hard coated with melamine silver metallic resin (Silver color).
② Shelf	: Steel board 3pcs
③ Hygrometer	: Analogue Dual, humidity shown both inside (upper indicator) and outside (bottom indicator) housing
④ Door	: Steel, with clear glass and magnetic packing.
⑤ Handle	: Lock with key (2pcs)
⑥ Operation check lamp	: (TOP/Green lamp Lighting:absorption, MIDDLE/Red lamp Lighting: Reproduction exhaust, BOTTOM/Red lamp Lighting:For internal humidity Warning)
⑦ Dry unit	: Large dehumidifier, desiccant system, latest high and technological Memory, alloy, IC timer, with a humidity controller for only dehumidifying
⑧ Storage box	: Storage box for a power supply and a terminal board
⑨ Magnet paking	: Door packing with magnet ensures air tightness
⑩ Spare screw	: Connection screw, wall hung tip-resistant hook.
⑪ Pillar for hook	: For setting shelf board
⑫ Shutter cover	: Guard shutter cover for dry-unit exhaustin
⑬ Power source	: AC100~120V 50/60Hz 6W/H AC220~240V 50/60Hz 6W/H With outlet for use in cabinet, and 1MΩ earth cord Energy saving dehumidifying system, 460 minutes-cycle system starting with 40 minutes exhaust and 60 minutes cooling, then 360 minutes moisture absorption.
Weight	: 28Kg



*Note: Specification are subject to change without notice