

# Dual hygrometer(Analogue) TDC-155-SDX (Capacity 145L)

## NOMENCLATURE

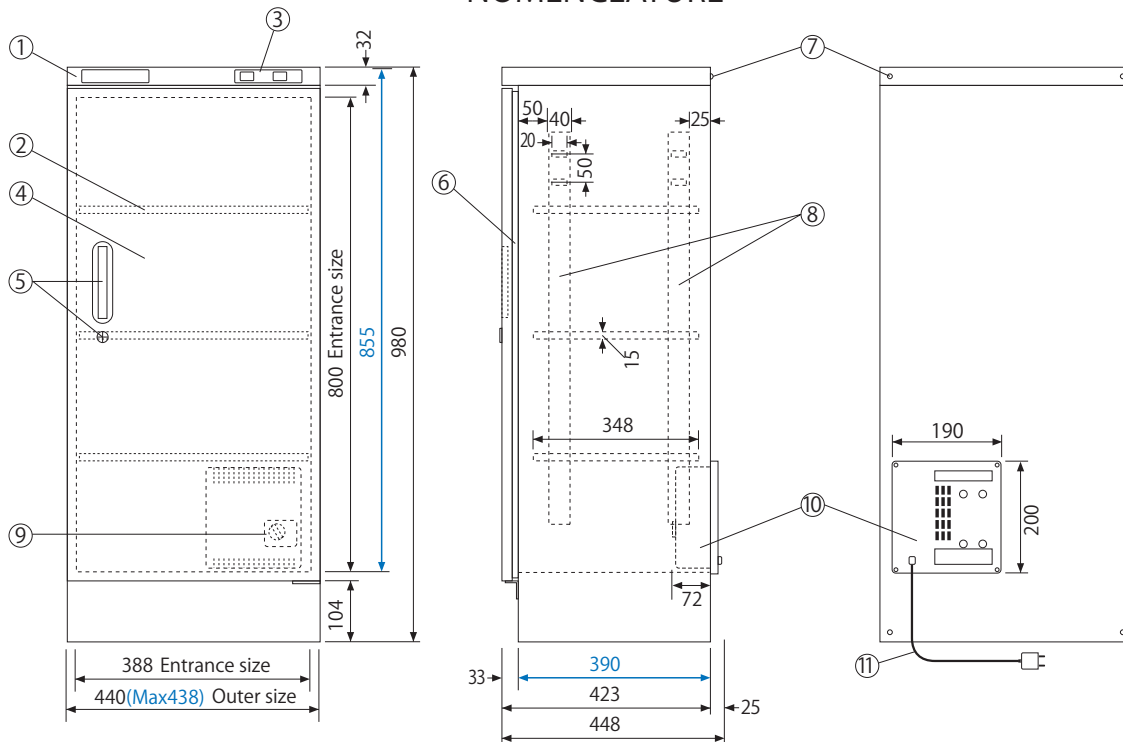

- ◆ **Blue number** indicates the dimensions of storage space.
- ◆ Each shelf board is adjustable, and is removable for your convenience.

Name	Specification
① Cabinet	: High quality steel plate (0.8mm), hard coated with melamine silver metallic resin (Silver color).
② Shelf	: Steel board 3pcs
③ Hygrometer	: Digital Dual LED hygrometer, humidity shown both inside and outside housing
④ Door	: Steel made, with magnetic packing.
⑤ Handle	: Lock with key (2pcs)
⑥ Magnet paking	: Door packing with magnet ensures air tightness
⑦ Spare screw	: Double layer connection screw, wall hung tip-resistant hook.
⑧ Pillar for hook	: For setting shelf board
⑨ Controller	: Humidity controller
⑩ Dry unit	: Dehumidifier, desiccant system, latest high and technological Memory alloy, IC timer, with Humidity controller for only dehumidifying.
⑪ Power source	: AC100~120V 50/60Hz 0.3W/H~3.6W/H (Max 120W/moment) AC220~240V 50/60Hz 0.15W/H~1.8W/H (Max 60W/moment) The absorption & ventilation cycle of new drying unit upgraded to 4 hours (3 hours and 30 minutes absorption and 30 minutes ventilation).
Weight	: 25Kg



\*Note: Specification are subject to change without notice