

Dual hygrometer(Analogue) TDC-150-AX (Capacity 145L)

NOMENCLATURE

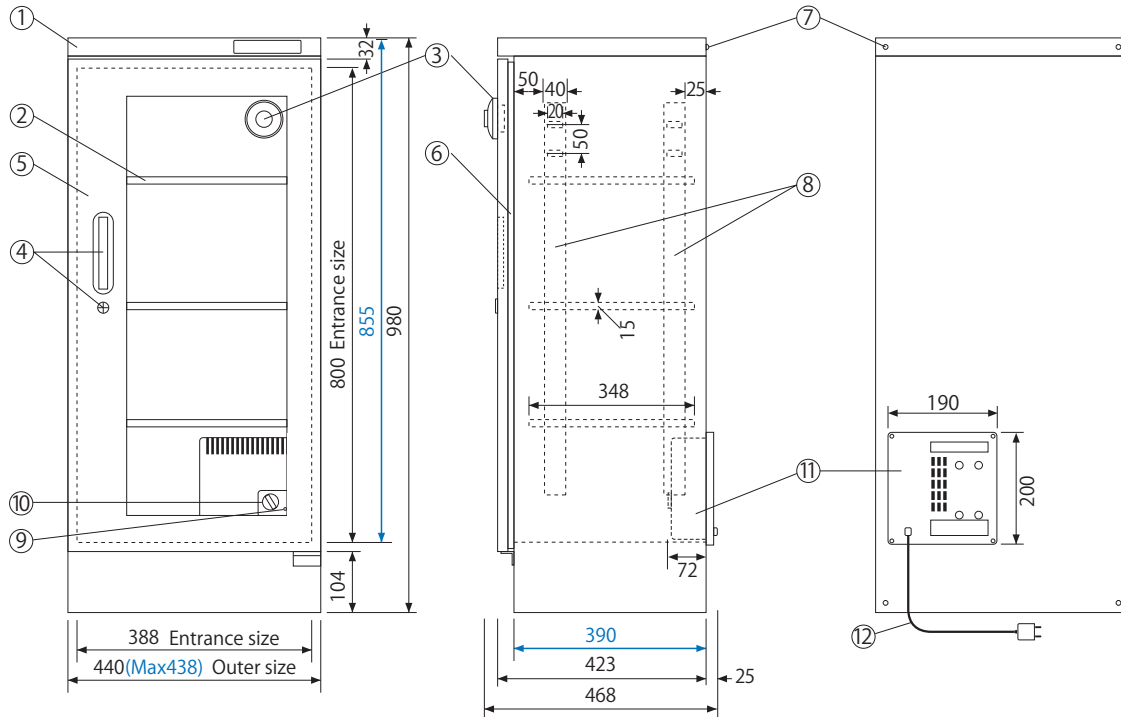

- ◆ **Blue number** indicates the dimensions of storage space.
- ◆ Each shelf board is adjustable, and is removable for your convenience.

Name	Specification
① Cabinet	: High quality steel plate (0.8mm), hard coated with melamine silver metallic resin (Silver color).
② Shelf	: Steel board 3pcs
③ Hygrometer	: Analogue Dual, humidity shown both inside (upper indicator) and outside (bottom indicator) housing
④ Handle	: Lock with key (2pcs)
⑤ Door	: Steel made, with clear glass and magnetic packing.
⑥ Magnet packing	: Door packing with magnet ensures air tightness
⑦ Spare screw	: Double layer connection screw, wall hung tip-resistant hook.
⑧ Pillar for hook	: For setting shelf board
⑨ Pilot lamp	: Lighting during the exhaust, lights out during the moisture absorption
⑩ Controller	: Humidity controller
⑪ Dry unit	: Dehumidifier, desiccant system, latest high and technological Memory alloy, IC timer, with Humidity controller for only dehumidifying.
⑫ Power source	: AC100~120V 50/60Hz 0~3.6W/H (Max 120W/moment) AC220~240V 50/60Hz 0~1.8W/H (Max 60W/moment) The absorption & ventilation cycle of new drying unit upgraded to 4 hours (3 hours and 30 minutes absorption and 30 minutes ventilation).
Weight	: 25Kg



*Note: Specification are subject to change without notice

Since 1983
TOLIHAN CORP.

An inquiry, the communication by E-mail.

E-mail info@dry-cabi.co.jp

21-6, Higashi-Ueno, 3-chome, Taiko-ku, Tokyo Japan 110-0015
Phone:81-3-3833-0614 Fax:81-3-3833-0616

URL <http://www.dry-cabi.co.jp/english.html>