

ULTRA LOW Humidity  
Digital Dual LED Hygrometer  
**TDC-1319-SDD** (Capacity 1,261L)

NOMENCLATURE

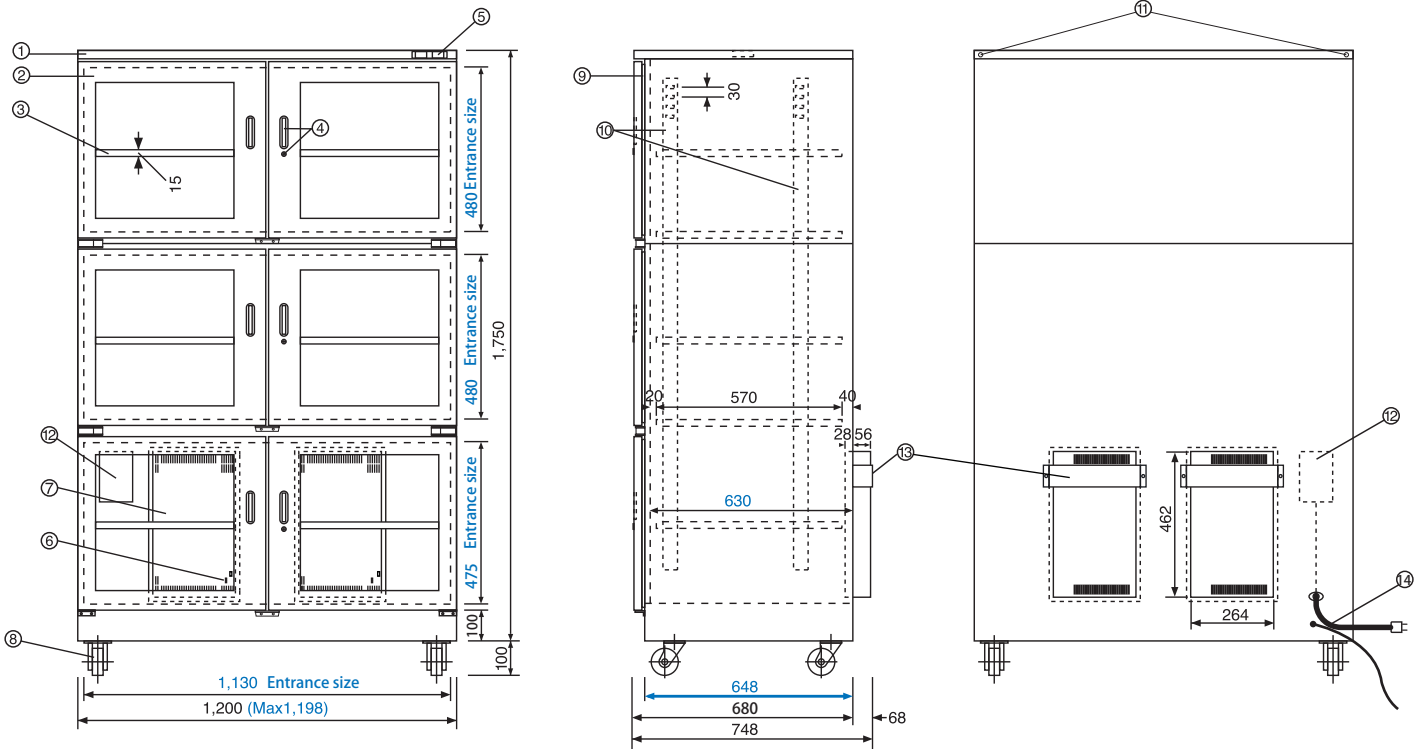

- ◆ **Blue number** indicates the dimensions of storage space.
- ◆ Each shelf board is adjustable, and is removable for your convenience.

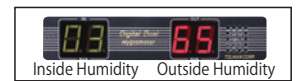

Name	Specification
① Cabinet	: High quality steel plate (1.0mm), hard coated with melamine silver metallic resin (Silver color).
② Door	: 6 Doors, steel, with clear glass and magnetic packing.
③ Shelf	: Steel board 5pcs
④ Handle	: 6 Handles, 3 locks with key (2pcs)
⑤ Hygrometer	: Analogue Dual, humidity shown both inside (upper indicator) and outside (bottom indicator) housing
⑥ Operation check lamp	: (TOP/Green lamp Lighting:absorption, MIDDLE/Red lamp Lighting: Reproduction exhaust, BOTTOM/Red lamp Lighting:For internal humidity Warning)
⑦ Dry unit	: Large dehumidifier, desiccant system, latest high and technological Memory, alloy, IC timer, with a humidity controller for only dehumidifing.
⑧ Caster	: 4 casters, with stopper only front 2 casters
⑨ Magnet paking	: Door packing with magnet ensures air tightness
⑩ Pillar for hook	: For setting shelf board
⑪ Spare screw	: Connection screw, wall hung tip-resistant hook.
⑫ Storage box	: Storage box for a power supply and a terminal board
⑬ Shutter cover	: Guard shutter cover for dry-unit exhaust
⑭ Power source	: AC100~120V 50/60Hz 0.5~47W/H (Max 370W/moment) AC220~240V 50/60Hz 0.25~23.5W/H (Max 185W/moment) With outlet for use in cabinet, and 1MΩ earth cord Energy saving dehumidifying system, 460 minutes-cycle system-starting with 40 minutes exhaust and 60 minutes cooling, then 360 minutes moisture absorption.
Weight	: 145Kg



\*Note: Specification are subject to change without notice