

WET-CABI Humidify  
TDC-1310-AHU (Capacity 1,261L)

NOMENCLATURE

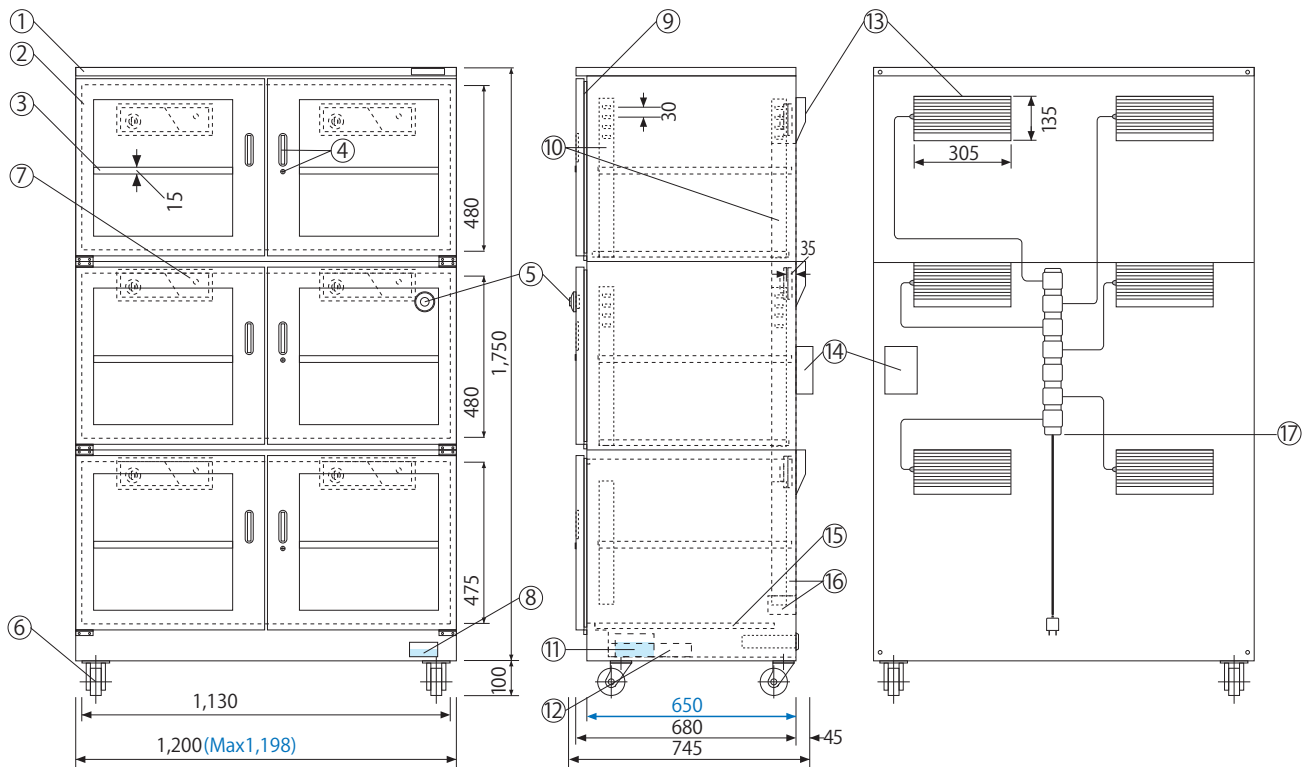

- ◆ Blue number are the dimensions of storage space.
- ◆ Each shelf board is adjustable, and is removal for your convenience.

Name	Specification
① Cabinet	: High quality steel plate (1.0mm), hard coated with melamine silver metallic resin (Silver color).
② Door	: 6 doors, steel made, with clear glass and magnetic packing.
③ Shelf	: Steel board 5pcs
④ Handle	: 6 handles, 3 locks with key (2pcs)
⑤ Hygrometer	: Analogue Dual, humidity shown both inside (upper indicator) and outside (bottom indicator) housing
⑥ Caster	: Front casters with stopper
⑦ Pilot lamp	: Lighting during the exhaust, lights out during the moisture absorption
⑧ Window	: Water level confirmation window
⑨ Magnet packing	: Door packing with magnet ensures air tightness
⑩ Pillar for hook	: For setting shelf board
⑪ Tray	: Water container for humidification
⑫ Tray	: Tray for overspill prevention of the water for humidification
⑬ Dry unit (6)	: Thermo Module Dehumidifying System, with a humidity controller
⑭ Time switch	: Timer for Fan ON/OFF
⑮ Bottom plate	: Steel with punting hole for air circulation
⑯ Fan	: Fan for circulating in the storage. 6W/H.
⑰ Power source	: AC100~120V 50/60Hz 0W/H~67W/H AC220~240V 50/60Hz 0W/H~33W/H Energy saving dehumidifying system
Weight	: 160Kg



\*Note: Specification are subject to change without notice