

Space-saving Shallow type Analogue hygrometer

NT-83-MIIWH (Capacity 46L)

NOMENCLATURE

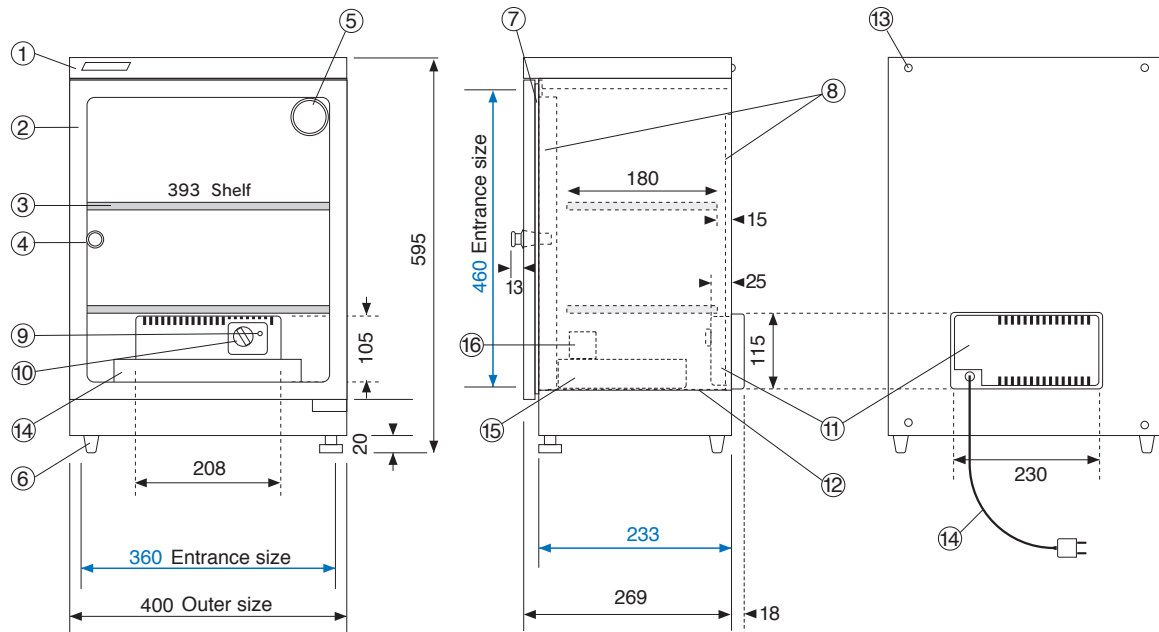

- ◆ Blue number indicates the dimensions of storage space.
- ◆ Each shelf board is adjustable, and is removable for your convenience.

Name	Specification
① Cabinet	: High quality steel plate (0.8mm), hard coated with melamine resin (White color).
② Door	: PVC flame, clear tempered glass with the corner of silk screen printed, magnetic packing.
③ Shelf	: 2 steel boards covered with the Photocatalytec gray cushion sheets.
④ Lock-Handle	: Handle with key (2pcs)
⑤ Hygrometer	: Analogue display inside, with thermometer
⑥ Foot	: With adjuster (front right) rubber foot.
⑦ Door packing	: Magnet PVC edge, ensures air tightness
⑧ Pillar for hook	: For setting shelf board (4pillars)
⑨ Pilot lamp	: Lighting during the exhaust, lights out during the moisture absorption
⑩ Controller	: Humidity controller
⑪ Dehumidifier	: Desiccant system, latest high and technological Memory alloy, IC timer, with a humidity controller for only dehumidifying.
⑫ Bottom plate	: Steel
⑬ Spare screw	: Double layer connection screw, wall hung tip-resistant hook.
⑭ Power source	: AC100~120V 50/60Hz 1.54W/H AC220~240V 50/60Hz 0.77W/H The absorption & ventilation cycle of new drying unit upgraded to 4 hours (3 hours and 30 minutes absorption and 30 minutes ventilation).
⑮ Accessories	: Plastic tray
⑯ Nameplate	: YES
Weight	: 10Kg



*Note: Specification are subject to change without notice