

# Digital Dual LED Hygrometer Special Series H-205WD-MII (Capacity 203L)

## NOMENCLATURE

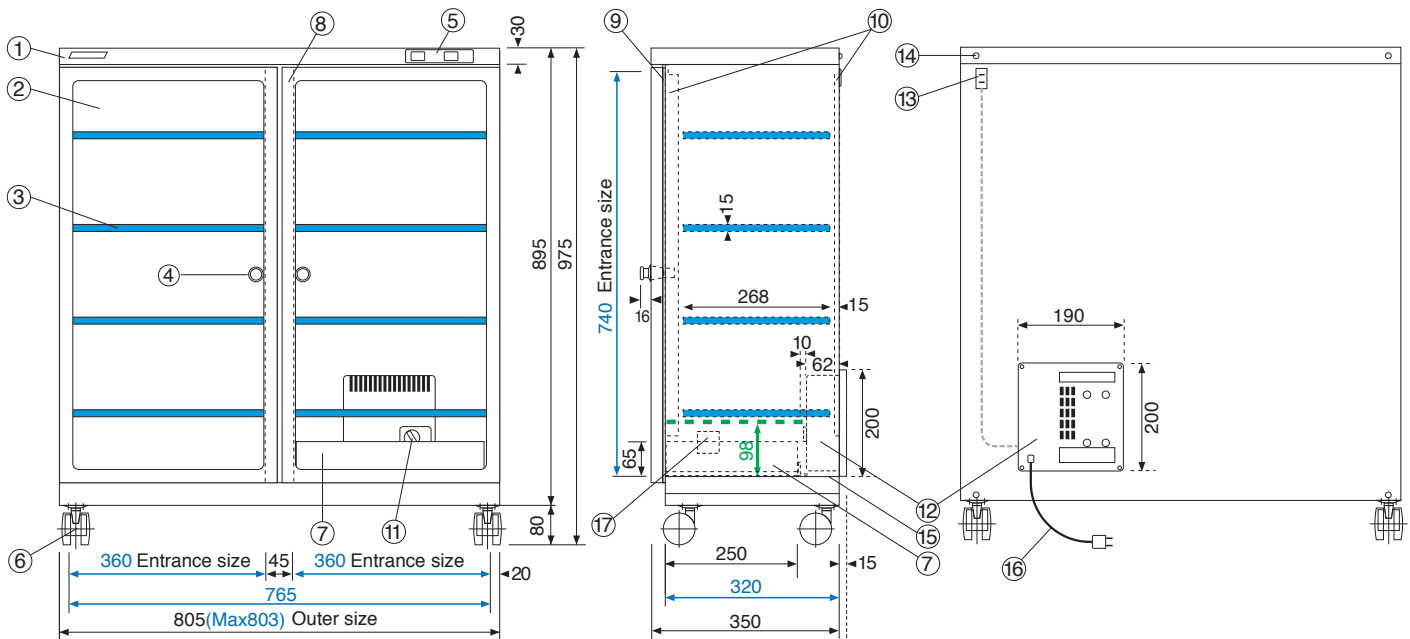

- ◆ **Blue number** indicates the dimensions of storage space.
- ◆ **Green arrow** shows the minimum position between the shelf and the bottom. Each shelf board is adjustable, and is removable for your convenience.

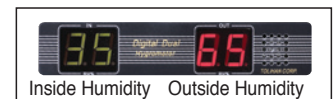

Name	Specification
① Cabinet	: High quality steel plate (0.8mm), hard coated with melamine resin (Black color).
② Door	: 2 doors PVC flame, clear tempered glass with the corner of silk screen printed, magnetic packing.
③ Shelf	: 4 steel boards covered with the Photocatalytec navy blue cushion sheets.
④ Lock-Handle	: 2 Handles with key (2pcs)
⑤ Hygrometer	: Digital Dual LED hygrometer, humidity shown both inside and outside housing
⑥ Caster	: 4 casters, with stopper only front 2 casters
⑦ Tray	: Steel tray is convenient as a pouch 1pc, with plastic tray for battery charging.
⑧ Center Pillar	: When put a long lens, are removable, take off an upper screw of the backside of the pillar and lift a pillar on the top and go down before
⑨ Door packing	: Magnet PVC edge, ensures air tightness
⑩ Pillar for hook	: For setting shelf board (4 pillars)
⑪ Controller	: Humidity controller
⑫ Dehumidifier	: Desiccant system, latest high and technological Memory alloy, IC timer, with a humidity controller for only dehumidifying.
⑬ Top outlet	: User friendly top outlet helps battery charging (Max 500W/H)
⑭ Spare screw	: Double layer connection screw, wall hung tip-resistant hook.
⑮ Bottom plate	: Steel
⑯ Power source	: AC100~120V 50/60Hz 0.3~3.6W/H AC220~240V 50/60Hz 0.15~1.8W/H The absorption & ventilation cycle of new drying unit upgraded to 4 hours (3 hours and 30 minutes absorption and 30 minutes ventilation).
⑰ Nameplate	: YES
Weight	: 36Kg



\*Note: Specification are subject to change without notice

Since 1983  
**TOLIHAN CORP.**

An inquiry, the communication by E-mail.  
E-mail [info@dry-cabi.co.jp](mailto:info@dry-cabi.co.jp)

21-6, Higashi-Ueno, 3-chome, Taiko-ku, Tokyo Japan 110-0015  
Phone:81-3-3833-0614 Fax:81-3-3833-0616

URL <http://www.dry-cabi.co.jp/english.html>